

Movorail components data

Figure	Designation	Use with rail size	Remark	Part number	Notes
<p>Rail profiles</p> <p>SPR 85 </p> <p>SPR 125 </p> <p>SPR 160A </p> <p>SPR 295B and SPR 295W </p> <p>B = bolted W = welded</p>	SPR 85-4	–	L = 4 m	D108 614	
	SPR 85-5	–	L = 5 m	D108 615	
	SPR 85-6	–	L = 6 m	D108 616	
	SPR 85-8	–	L = 8 m	D108 618	
	SPR 85-•	–	L = specify length		
	SPR 125-4	–	L = 4 m	D100 214	
	SPR 125-5	–	L = 5 m	D100 215	
	SPR 125-6	–	L = 6 m	D100 216	
	SPR 125-8	–	L = 8 m	D100 218	
	SPR 125-•	–	L = specify length		
	SPR 160A-4	–	L = 4 m	D100 254	
	SPR 160A-5	–	L = 5 m	D100 255	
	SPR 160A-6	–	L = 6 m	D100 256	
	SPR 160A-8	–	L = 8 m	D100 258	
	SPR 160A-•	–	L = specify length		
	SPR 295B-4	–	L = 4 m	D119 204	
	SPR 295B-5	–	L = 5 m	D119 205	
	SPR 295B-6	–	L = 6 m	D119 206	
	SPR 295B-8	–	L = 8 m	D119 208	
	SPR 295B-•	–	L = specify length		
SPR 295W-4	–	L = 4 m	D119 304		
SPR 295W-5	–	L = 5 m	D119 305		
SPR 295W-6	–	L = 6 m	D119 306		
SPR 295W-8	–	L = 8 m	D119 308		
SPR 295W-•	–	L = specify length			
<p>Curved rail profiles</p> 	SPB 85-90	SPR 85	Angle = 90°	D108 629	
	SPB 85-••	SPR 85	Angle = specify angle		
	SPB 125-90	SPR 125	Angle = 90°	D100 239	
	SPB 125-••	SPR 125	Angle = specify angle		
	SPB 160A-90	SPR 160A	Angle = 90°	D100 269	
	SPB 160A-••	SPR 160A	Angle = specify angle		
<p>Rail connections</p> 	SK 85R	SPR 85	For straight rails	D114 410	
	SK 125/160AR	SPR 125/160A/295B(W)	For straight rails	D103 830	
	SK 85R/B	SPR 85	For straight to curved rails	D114 910	
	SK 125/160AR/B	SPR 125/160A/295B(W)	For straight to curved rails	D116 230	
<p>T-slot bolts</p> 	TBM 8-28	SPR 85	M8, h = 24 mm	D111 620	
	TBM 8-45	SPR 85	M8, h = 41 mm	D111 615	
	TBM 12-32	SPR 125/160A/295B(W)	M12, h = 26 mm	D102 510	
	TBM 12-48	SPR 125/160A/295B(W)	M12, h = 42 mm	D102 525	
	TBM 12-95	SPR 125/160A/295B(W)	M12, h = 89 mm	D102 515	

Movorail components data

Figure	Designation	Use with rail size	Remark	Part number	Notes
I-beam clamps 	VBKLA 85	SPR 85	Pair. Max. load 1000 N	D101 048	
	VBKLA 125/160A	SPR 125/160A/295B(W)	Pair. Max. load 6000 N	D101 047	
Flexible suspensions  <p>DBSU 85-100 Mounting on rail or connection</p> <p>DBSU 125/160A-600 Mounting on rail or connection</p>	DBSU 85-100*	SPR 85	Max. load 1000 N	D106 202	
	DBSU 125/160A-600*	SPR 125/160A/295B(W)	Max. load 6000 N	D106 209	
* The suspension can be installed in any direction in relation to the I-beam					
Adjustable suspensions  <p>Mounting on rail or connection</p>	ASU 125/160A-600	SPR 125/160A/295B(W)	Max. load 6000 N	D106 215	
	* The suspension can be installed in any direction in relation to the I-beam and is adjustable 50 mm in height				
Z-suspensions 	DZ 85	SPR 85	Max. load 1000 N	D116 810	
	DZ 125/160A	SPR 125/160A/295B(W)	Max. load 6000 N	D116 410	
Universal safety cables  <p>Cable length = 1500 mm</p>	SLU4	SPR 85	Cable diameter = 4 mm	D190 605	
	SLU6	SPR 125/160A/295B(W)	Cable diameter = 6 mm	D190 604	
Endplates 	TPL 85	SPR 85	STP or EPF required for mounting	D107 410	
	TPL 125	SPR 125	STP or EPF required for mounting	D103 720	
	TPL 160A	SPR 160A/295B(W)	STP or EPF required for mounting	D103 730	
Endstops (STP), Endplate supports (EPF) and Walter bolts (WBM)  <p>STP WBM EPF</p>	STP 85	SPR 85	With rubber bumper	D107 110	
	STP 125/160A	SPR 125/160A/295B(W)	With rubber bumper	D102 910	
	EPF 85/125/160A	For all sizes	No rubber bumper	D102 915	
	WBM 12	For all sizes	Secure position of STP in the rail	D102 912	

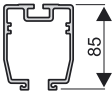
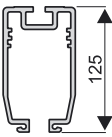
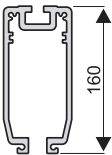
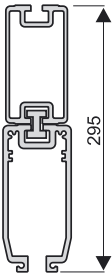
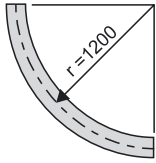
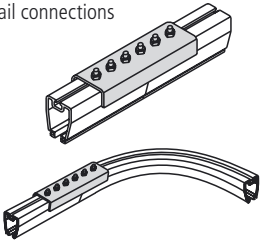
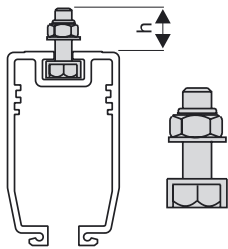
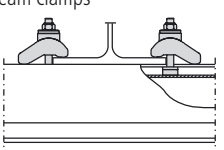
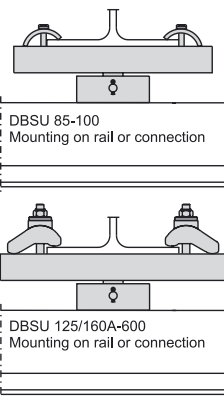
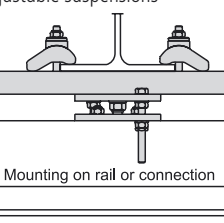
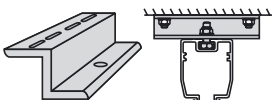
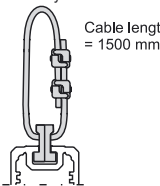
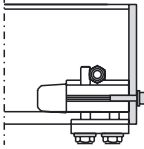
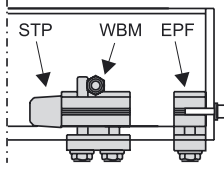

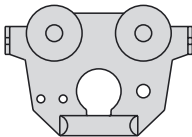
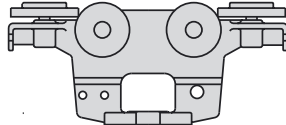
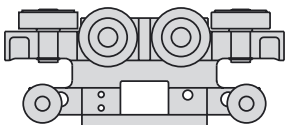
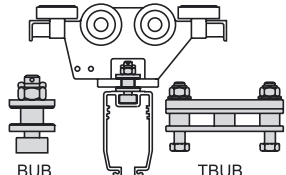
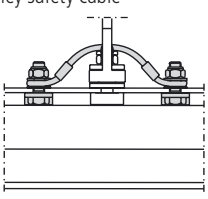
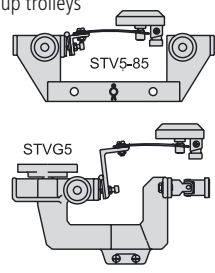
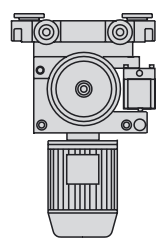
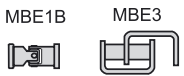

Movorail components data

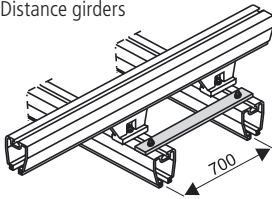
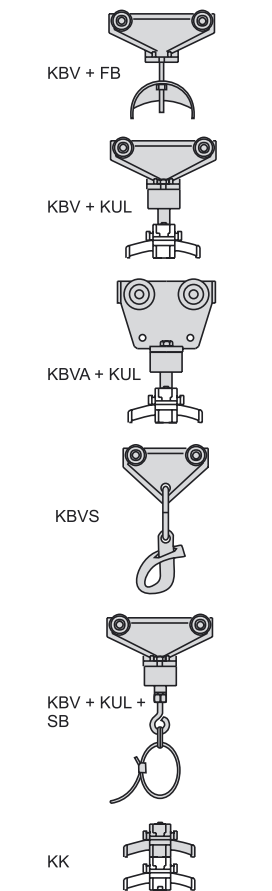
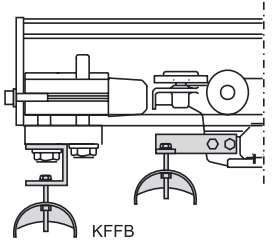
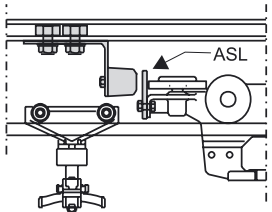
Figure	Designation	Use with rail size	Remark	Part number	Notes
Crab trolleys 	LPV 100 A	For all sizes	Max. load 1000 N	D125 610	
	LPV 100 B*	For all sizes	Max. load 1000 N	D125 620	
	LPV 300 A	SPR 125/160A/295B(W)	Max. load 6000 N	D104 520	
	* This trolley can not be used in combination with current rail in rail size SPR 85				
Bogie trolleys 	BGV 100 E	For all sizes	Max. load 1000 N	D115 210	
	BGV 100 G*	For all sizes	Max. load 1000 N	D115 220	
	BGV 300 C	SPR 125/160A/295B(W)	Max. load 6000 N	D117 330	
	* This trolley can not be used in combination with current rail in rail size SPR 85				
Bogie trolleys with rollers 	BGV 100 LS*	SPR 85	Max. load 1000 N	D115 242	
	BGV 100 KS	SPR 125	Max. load 1000 N	D115 241	
	BGV 100 JS	SPR 160A/295B(W)	Max. load 1000 N	D115 240	
	BGV 300 HSE	SPR 125/160A/295B(W)	Max. load 6000 N**	D117 341	
	* This trolley can not be used in combination with current rail in rail size SPR 85 **Max. load is 3000 N when used with rail size SPR125				
Flexible bolt connections 	BUB 85	SPR 85	One SLV4 is included	D105 720	
	BUB 125/160A	SPR 125/160A/295B(W)	One SLV6 is included	D105 710	
	TBUB12	SPR 125/160A/295B(W)		D105 715	
Trolley safety cable 	SLV4	SPR 85	Cable diameter = 4 mm	D190 601	
	SLV6	SPR 125/160A/295B(W)	Cable diameter = 6 mm	D190 600	
Pick up trolleys 	STV5-85	SPR 85	Max. 10 A @ 60 % ED	D121 910	
	STVG5-125*	SPR 125	Max. 10 A @ 60 % ED	D121 940	
	STVG5-160A*	SPR 160A/295B(W)	Max. 10 A @ 60 % ED	D121 945	
	* This type of pick up trolley must be connected to a LPV or BGV trolley and is shipped with a MBE1B type of trolley cardan joint.				
Motor trolleys 	TMT	SPR 125/160A/295B(W)	See page 10 and 11 for technical data and ordering key		
Trolley cardan joints 	MBE1B*	–	Can be used with curved rails	D119 920	
	MBE3*	–	For use with straight rails only	D119 930	
	* A trolley cardan joint is used to connect a pick up trolley or a motor trolley to a LPV or a BGV trolley				

Movorail components data

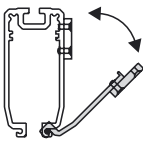
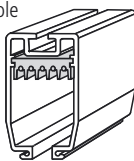
Figure	Designation	Use with rail size	Remark	Part number	Notes	
	DNS 125/160A-700	SPR 125/160A/295B(W)	Flexible connection of two crane rails	D125 410		
	SD 125/160A-700	SPR 125/160A/295B(W)	Rigid connection of two crane rails	D125 470		
	KBV + FB	For all sizes	Trolley with flat cable clamp	D190 512		
	KBV + KUL	For all sizes	Trolley with ball joint (KK needed)	D190 511		
	KBVA + KUL	For all sizes	Trolley with ball joint (KK needed)	D126 809		
	KBVS	For all sizes	Trolley with strap for round cables	D190 520		
	KBV + KUL + SB	For all sizes	Trolley for hoses ø 30 - 80 mm	D190 513		
	KK 10-16*	-	Clamp for cables ø 10 - 16 mm	D126 816		
	KK 17-25*	-	Clamp for cables ø 17 - 25 mm	D126 817		
	KK 26-36*	-	Clamp for cables ø 26 - 36 mm	D126 818		
	* KK clamps can be stacked on to each other. On a KBV + KUL a maximum of two clamps can be stacked. On a KBVA + KUL an unlimited number of clamps can be stacked as long as the load does not exceed 50 kg.					
	KFFB	For all sizes	For attachment of KBV + FB	D190 508		
	KFKK	For all sizes	For attachment of KBV + KUL	D190 507		
	KFVS	For all sizes	For attachment of KBVS	D190 521		
	KFSB	For all sizes	For attachment of KBV + KUL + SB	D190 509		
	BGR 85*	SPR 86	ASL included	D107 930		
	BGR 125*	SPR 125	ASL included	D107 920		
	BGR 160A*	SPR 160A/295B(W)	ASL included	D107 910		
	* Motion limiters are used to stop LPV, BGV or TMT trolleys before they reach the end of the rail. The distance between the motion limiter and the end of the rail can be used for cable trolleys or to restrict the access for trolleys to certain areas.					

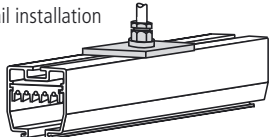
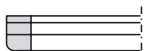
Movorail components data

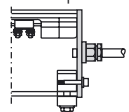
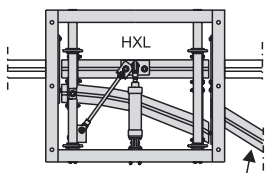
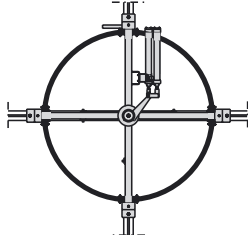
Figure	Designation	Use with rail size	Remark	Part number	Notes
Service sections 	SSKT 125*	SPR 125		D180 020	
	SSKT 160A*	SPR 160A/295B(W)		D180 030	
* The exact position where the service section should be placed on the rail must be specified.					
Current tracks, 5 pole 	SB 5-4	For all sizes	L = 4 m / Max. current = 55 A	D190 110	
	SB 5-1	For all sizes	L = 1 m / Max. current = 55 A	D190 109	
	SB 5.90.1200	For all 90° curves	Radius = 1,2 m / Max. current = 55 A	D190 113	
Power supply current track for installation at the rail end 	ATSA 5	For all sizes	L = 1 m / Max. current = 25 A	D190 310	
Power supply current track for mid rail installation 	TPI 5-125/160A	SPR 125/160A	Max. current = 25 A	D190 117	
	* The exact position where the cable gland plate should be placed on the rail must be specified.				
Current track end 	EST 5 + LED 5	For all sizes	Included in ATSA 5	D190 115	
Current track joint connection 	ATSK 5	For all sizes	Max. current = 25 A	D190 116	
Cable gland end plates 	TPLH 85	SPR 85	EFP or STP required for mounting	D107 420	
	TPLH 125	SPR 125	EFP or STP required for mounting	D103 740	
	TPLH 160A	SPR 160A/295B(W)	EFP or STP required for mounting	D103 750	
Pneumatic switches  <p>Connection rail included, L = 1 m</p>	HXL 85	SPR 85	Right turn (shown in picture)	D180 113	
	HXL 125	SPR 125	Right turn (shown in picture)	D180 123	
	HXL 160A	SPR 160A/295B(W)	Right turn (shown in picture)	D180 133	
	VXL 85	SPR 85	Left turn	D180 112	
	VXL 125	SPR 125	Left turn	D180 122	
	VXL 160A	SPR 160A/295B(W)	Left turn	D180 132	
Pneumatic switch current track kits	SBHX	–	For use in all HXL / TPI 5 included	D180 141	
	SBVX	–	For use in all VXL / TPI 5 included	D180 140	
Pneumatic turntables 	VSL 85	SPR 85		D180 211	
	VSL 125	SPR 125		D180 221	
	VSL 160A	SPR 160A/295B(W)		D180 231	
Turntable current track kit	SBVS	–	For use in all VSL / TPI 5 included	D180 240	
Load sign	–	For all sizes	Sticker	D301 114	

Dimensions

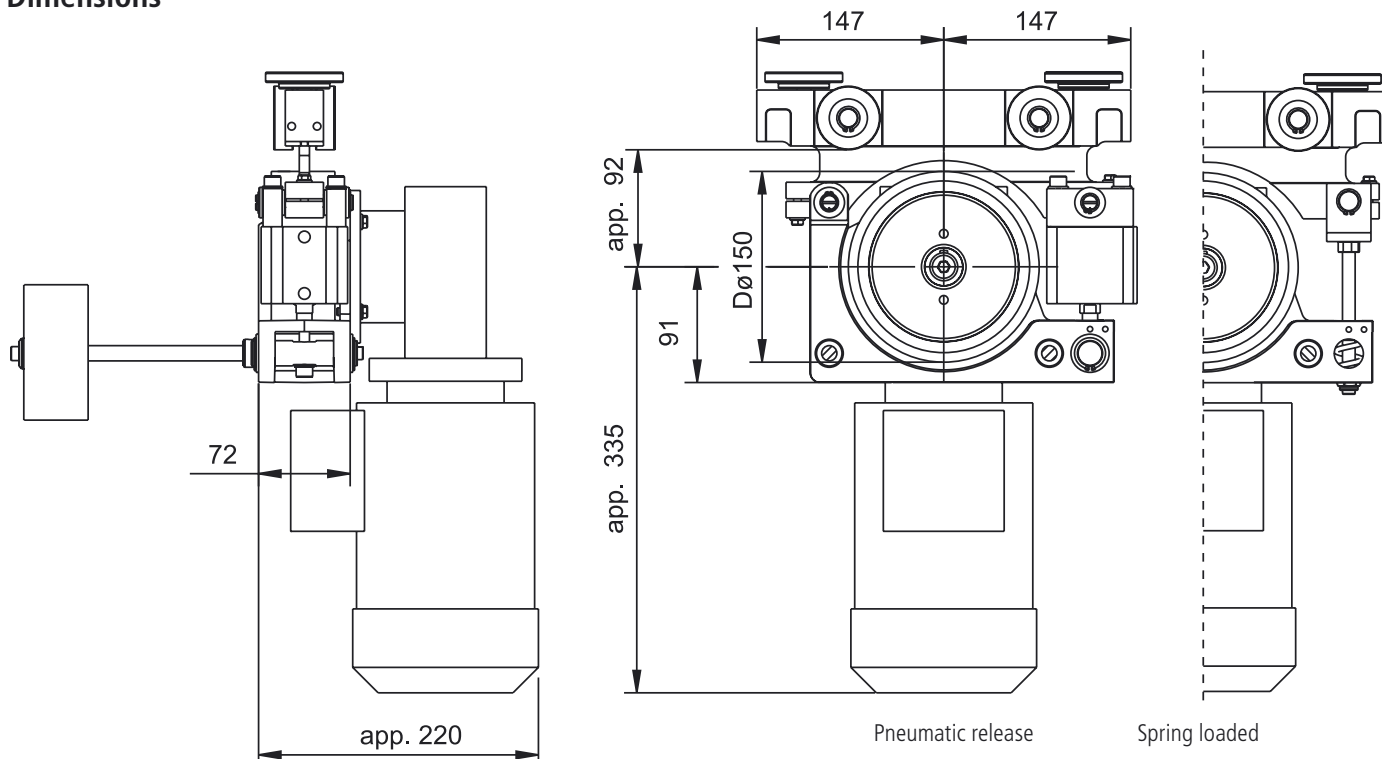

Spring setting and adjustment for rail size

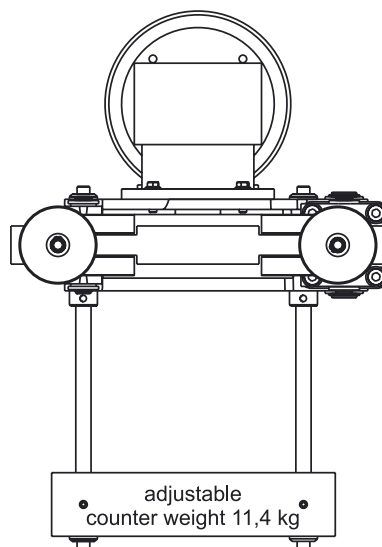
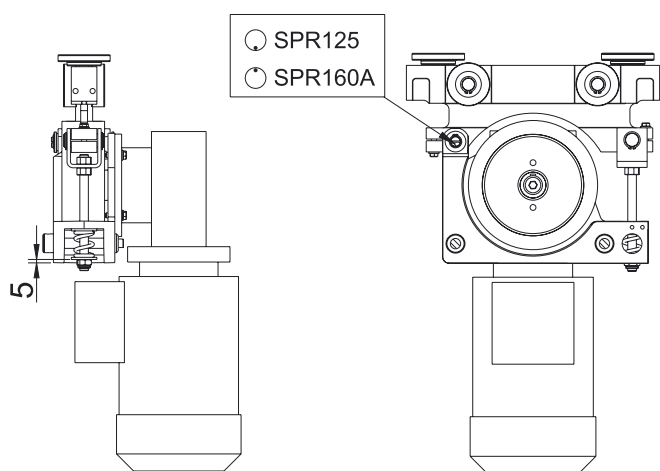

Trolley joints

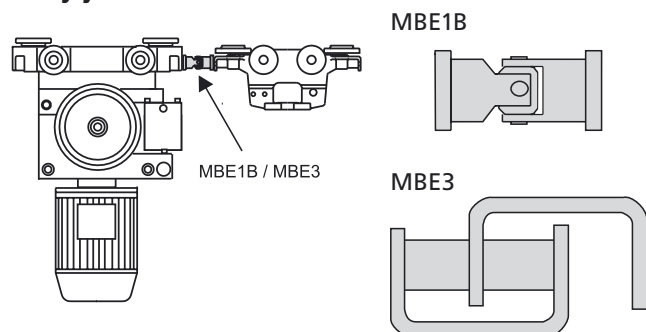

MBE1B - for straight and curved rails, p/n D119 920
 MBE3 - for straight rails only, p/n D119 930

Pneumatic cylinder sensor bracket

The sensor bracket is mounted on the motor trolley and can hold a cylindrical sensor that will indicate the position of the pneumatic cylinder.

p/n D120 190

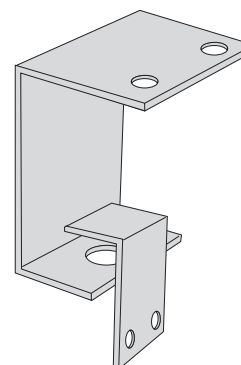

Ordering key for trolley with motor

Designation example	TMT	125	S	B	20	A	7	-2	N
Unit type Tollo Motor Trolley	TMT								
Profile type SPR 125 SPR 160A		125 160							
Type of TMT trolley With spring loaded drive wheel (standard) With pneumatically released drive wheel With spring and power pick up With pneumatic release and power pick up			S P T Q						
Colour Blue (standard) Yellow				B Y					
Speed of trolley at nominal motor rpm (v) 20 m/min 25 m/min 30 m/min 35 m/min 40 m/min 50 m/min 60 m/min					20 25 30 35 40 50 60				
Motor, gear and drive wheel configuration 400 Vac 3 phase SEW motor, SEW gear and drive wheel (standard)						A			
Motor size IEC 71 IEC 80							7 8		
Motor poles 2 pole 4 pole 8/2 pole (2 speed motor)								-2 -4 82	
Type of motor brake No brake Electromagnetic fail safe brake Electromagnetic fail safe brake with hand release									N B H

Ordering key for trolley without motor

Designation example	TMT	125	S	B	10	N • • •
Unit type Tollo Motor Trolley	TMT					
Profile type SPR 125 SPR 160A		125 160				
Type of TMT trolley With spring loaded drive wheel (standard) With pneumatically released drive wheel With spring and power pick up With pneumatic release and power pick up			S P T Q			
Colour Blue (standard) Yellow				B Y		
Gear ratio (i) - the worm gears comes with flange and coupling for IEC 71/B14 motors 00 (if no gear, use for code G • • • and H • • •) 10 15 20 24 30 40 48 60					00 10 15 20 24 30 40 48 60	
Motor, gear and drive wheel configuration No motor, with Benzler worm gear Without motor and gear, with drive wheel Without motor, gear and drive wheel						N • • • G • • • H • • •

Formulas

Calculation of trolley speed:

$$v = \frac{\text{rpm}_{\text{motor}} \times 3,14 \times 0,15}{i}$$

Calculation of gear ratio:

$$i = \frac{\text{rpm}_{\text{motor}} \times 3,14 \times 0,15}{v}$$

v = travel speed [m/min]
i = gear ratio

EUROPE

United Kingdom

Thomson
Office 9, The Barns
Caddsdawn Business Park
Bideford
Devon, EX39 3BT
Phone: +44 (0) 1271 334 500
E-mail: sales.uk@thomsonlinear.com

Germany

Thomson
Nürtinger Straße 70
72649 Wolfschlügen
Phone: +49 (0) 7022 504 0
Fax: +49 (0) 7022 504 405
E-mail: sales.germany@thomsonlinear.com

France

Thomson
Phone: +33 (0) 243 50 03 30
Fax: +33 (0) 243 50 03 39
E-mail: sales.france@thomsonlinear.com

Italy

Thomson
Largo Brughetti
20030 Bovisio Masciago
Phone: +39 0362 594260
Fax: +39 0362 594263
E-mail: sales.italy@thomsonlinear.com

Spain

Thomson
E-mail: sales.esm@thomsonlinear.com

Sweden

Thomson
Estridsväg 10
29109 Kristianstad
Phone: +46 (0) 44 24 67 00
Fax: +46 (0) 44 24 40 85
E-mail: sales.scandinavia@thomsonlinear.com

SOUTH AMERICA

Brasil

Thomson
Av. Tamboré, 1077
Barueri, SP – 06460-000
Phone: +55 (11) 3616-0191
Fax: +55 (11) 3611-1982
E-mail: sales.brasil@thomsonlinear.com

USA, CANADA and MEXICO

Thomson
203A West Rock Road
Radford, VA 24141, USA
Phone: 1-540-633-3549
Fax: 1-540-633-0294
E-mail: thomson@thomsonlinear.com
Literature: literature.thomsonlinear.com

ASIA

Asia Pacific

Thomson
E-mail: sales.apac@thomsonlinear.com

China

Thomson
Rm 2205, Scitech Tower
22 Jianguomen Wai Street
Beijing 100004
Phone: +86 400 6661 802
Fax: +86 10 6515 0263
E-mail: sales.china@thomsonlinear.com

India

Thomson
c/o Fluke Technologies Pvt. Ltd.
#424, Deodhar Center,
Marol Maroshi Road,
Andheri – E, Mumbai – 400059 India
Phone: +91 22 29207641
E-mail: sales.india@thomsonlinear.com

Japan

Thomson
Minami-Kaneden 2-12-23, Suita
Osaka 564-0044 Japan
Phone: +81-6-6386-8001
Fax: +81-6-6386-5022
E-mail: csjapan@scgap.com

Korea

Thomson
F7 Ilsong Bldg, 157-37
Samsung-dong, Kangnam-gu,
Seoul, Korea (135-090)
Phone: +82 2 6917 5049
Fax: +82 2 528 1456
E-mail: sales.korea@thomsonlinear.com

www.thomsonlinear.com

2004-SEP-21 | dw110442gb-0439 | 20160704SK
Errors and technical alterations reserved. It is the responsibility of the product user to determine the suitability of this product for a specific application. All trademarks property of their respective owners. © Thomson Industries, Inc. 2016



Linear Motion. Optimized.™